

Instructions for Use



CE
0297

PEOPLE HAVE PRIORITY



endea

Contra-angle handpieces

Endea Endo Cursor – EB-62

Endea – EB-75 / EB-79

endo

Contra-angle handpieces

Endo NiTi – WD-73 M / WD-74 M

Contents

Symbols	4
in the Instructions for use	4
on the medical device / packaging.....	5
1. Introduction	6
2. Safety notes	9
3. Product description	11
Endea Endo Cursor	11
Endea NiTi, Endea.....	12
4. Operation	13
Assembly / Removal	13
Changing the root canal instrument.....	15
Test run	16
5. Hygiene and maintenance	17
General notes	17
Limitations on processing.....	19

Initial treatment at the point of use.....	20
Manual cleaning.....	21
Automated cleaning and lubrication	22
Manual cleaning.....	23
Automated cleaning and disinfection.....	24
Drying	25
Inspection, Maintenance and Testing.....	26
Packaging.....	29
Sterilization	30
Storage.....	32
6. Servicing	33
7. W&H Accessories and spare parts	34
8. Technical data.....	35
9. Disposal	39
Explanation of warranty terms.....	40
Authorized W&H service partner	41



WARNING!
(risk of injury)



ATTENTION!
(to prevent
damage occurring)













General explanations,
without risk to
persons or objects



Do not dispose of with
domestic waste

Symbols

on the medical device / packaging

 CE marking with identification number of the Notified Body	 DataMatrix Code for product information including UDI (Unique Device Identification)	 Data structure in accordance with Health Industry Bar Code
 Catalogue number	 Thermo washer disinfectable	 Sterilizable up to the stated temperature
 Serial number	 UL Component Recognition Mark indicates compliance with Canadian and U.S. requirements	
 Date of manufacture	 Caution! According to Federal law, this medical device may only be sold by or on the order of a dentist, physician or any other medical practitioner licensed by the law of the State in which he or she practices and who intends to use or order the use of this medical device.	

1. Introduction

Customer satisfaction has absolute priority in the W&H quality policy. This medical device has been developed, manufactured and subjected to final inspection according to legal regulations, quality and industry standards.

For your safety and the safety of your patients

Prior to initial use please read the Instructions for use. These explain how to use your medical device and guarantee a smooth and efficient operation.



Observe the safety notes.

Intended use

Dental contra-angle handpiece for mechanical root canal preparation on patients, using rotary root canal instruments or root canal hand instruments with alternating 60° movement.



Misuse may damage the handpiece and hence cause risks and hazards for patient, user and third parties.

Qualifications of the user

We have based our development and design of the medical device on the dentists target group.

Production according to EU Directive

 The medical device meets the requirements of Directive 93/42/EEC.
0297

Responsibility of the manufacturer

The manufacturer can only accept responsibility for the safety, reliability and performance of the medical device when it is used in compliance with the following directions:

- > The medical device must be used in accordance with these Instructions for use.
- > The medical device has no components that can be repaired by the user.
- > Modifications or repairs must only be undertaken by an authorized W&H service partner (see page 41).

Skilled application

The medical device is intended only for skilled application according to the intended use as well as in compliance with the valid health and safety at work regulations, the valid accident prevention regulations and in compliance with these Instructions for use.

The medical device should be prepared for use and maintained by staff who have been trained in procedures for infection control, personal safety and patient safety.

Improper use, (e.g., through poor hygiene and maintenance), non-compliance with our instructions or the use of accessories and spare parts which are not approved by W&H, invalidates all claims under warranty and any other claims.

2.Safety notes



- > Before using the medical device for the first time, store it at room temperature for 24 hours.
- > The operation of the medical device is permitted only on supply units which correspond to the standards IEC 60601-1 (EN 60601-1) and IEC 60601-1-2 (EN 60601-1-2).
- > Always ensure the correct operating conditions and cooling function.
- > Check the medical device for damage and loose parts each time before using (e.g., push-button).
- > Do not operate the medical device if it is damaged.
- > Only attach the medical device onto the motor when the motor is at a complete standstill.
- > Do not activate the push-button of the medical device during operation. This leads to detachment of the root canal instrument and/or makes the medical device hot.
- > Perform a test run each time before using.
- > Do not touch the soft tissue with the contra-angle head (risk of burning due to the push-button heating up)!

Hygiene and maintenance prior to initial use



- > The medical device is sealed in PE film and not sterilized when delivered.
- > The PE film and the packaging are non-sterilizable.



- > Clean, disinfect and lubricate the medical device.
- > Sterilize the medical device.

3. Product description

Endea Endo Cursor

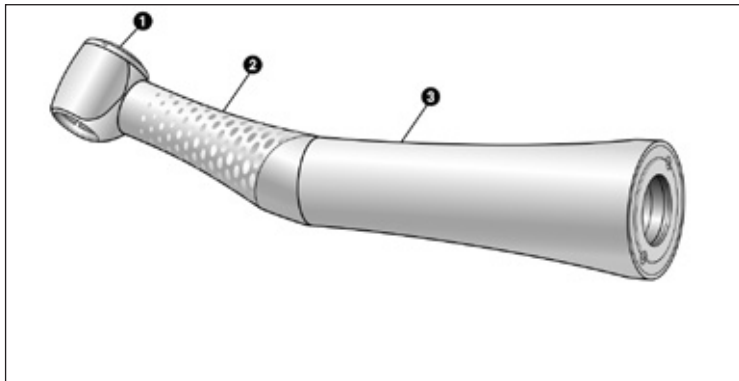

Endea Endo Cursor

- ① Push-button
- ② grip profile
- ③ sheath

3. Product description

Endea NiTi, Endea

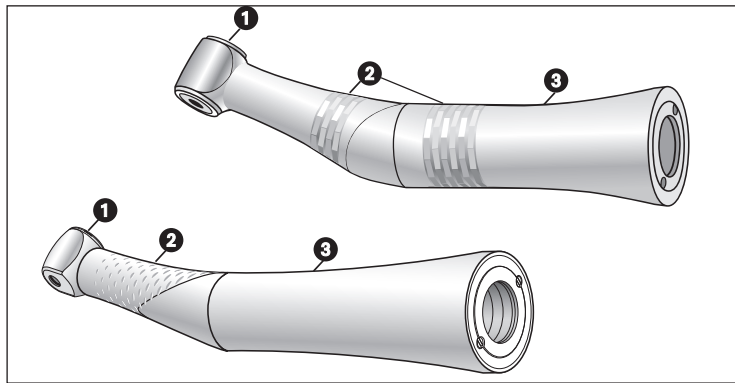

Endea NiTi
Endea

- ① push button
- ② grip profile
- ③ sheath

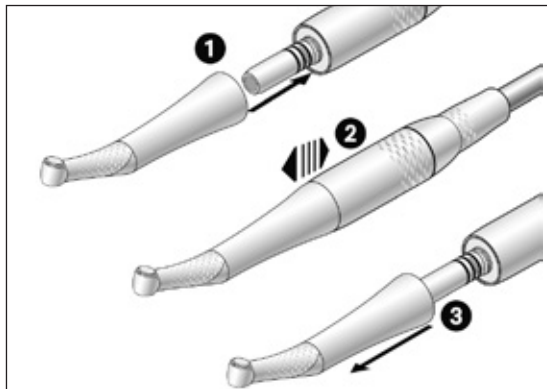

Do not assemble / remove the medical device during operation!

- 1** Fit the contra-angle handpiece onto the motor until it snaps into place.



- 2** Check the secure hold on the motor.

- 3** Remove the the medical device by pulling in an axial direction.

Root canal instrument



- > Use only perfect root canal instruments and follow the manufacturer's instructions.
- > Only insert the root canal instrument when the medical device is stationary.
- > Never touch the rotary instrument while it is still rotating.
- > Do not activate the push-button of the medical device during operation. This leads to detachment of the rotary instrument and/or makes the medical device hot.
- > W&H recommend the use of rubber dam.

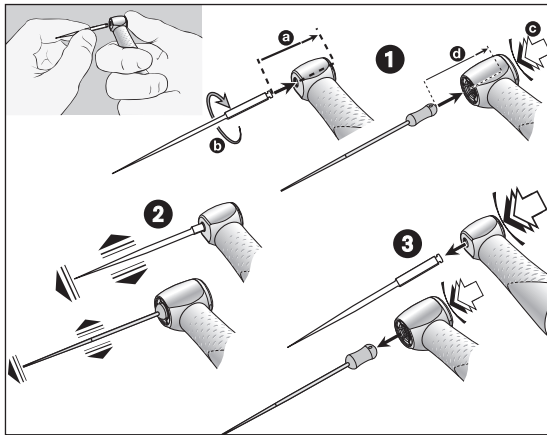

Changing the root canal instrument

- ❶ Endo NiTi / Endea: Insert root canal instrument until the limit stop [a] and turn until it engages [b].

Endea Endo Cursor: Insert the root canal hand instrument. Push the press button [c] firmly, at the same time insert the root canal hand instrument until limit stop [d].



- ❷ Verify full engagement.

- ❸ Remove the root canal instrument by pushing the push button.

Test run





Do not hold the medical device at eye level!

- > Insert the root canal instrument.
- > Start the medical device.



In the event of operating malfunctions (e.g., vibrations, unusual noise, overheating) **stop the medical device immediately** and contact an authorized W&H service partner.

 Follow your local and national laws, directives, standards and guidelines for cleaning, disinfection and sterilization.

 > Wear protective clothing, safety glasses, face mask and gloves.

 > Use only oil-free, filtered compressed air with a maximum operating pressure of 3 bar for manual drying.

Cleaning agents and disinfectants



- > Read the notes, follow the instructions and heed the warnings provided by the manufacturers of cleaning agents and/or disinfectants.
- > Use only detergents which are intended for cleaning and/or disinfecting medical devices made of metal and plastic.
- > It is imperative to comply with the concentrations and exposure times specified by the manufacturer of the disinfectant.
- > Use disinfectants which have been tested and found effective by the Verbund für Angewandte Hygiene e.V (VAH = Association for Applied Hygiene), the Österreichischen Gesellschaft für Hygiene, Mikrobiologie und Präventivmedizin (ÖGHMP = Austrian Society for Hygiene, Microbiology and Preventive Medicine), the Food and Drug Administration (FDA) and the U.S. Environmental Protection Agency (EPA).



The user is responsible for validating its process if the specified cleaning agents and disinfectants are not available.



The product lifetime and the medical device's ability to operate correctly are mainly determined by mechanical stress during use and chemical influences due to processing.

- > Send worn or damaged medical devices and/or medical devices with material changes to an authorized W&H service partner.



Processing cycles

- > We recommend a regular service for the W&H medical device after 1000 processing cycles or one year.



Clean the medical device immediately after every treatment, to flush out any liquid (e.g., blood, saliva etc.) and to prevent settling on the internal parts.

- > Operate the medical device for at least 10 seconds at idle speed.
- > Ensure that all outlets are rinsed out.



- > Wipe the entire surface of the instrument with disinfectant.
- > Remove the root canal instrument.
- > Remove the medical device.



Note that the disinfectant used during pre-treatment is only for personal protection and cannot replace the disinfectant step after cleaning.



Do not place the medical device in liquid disinfectant or in an ultrasonic bath.

- > Clean the medical device under running tap water (<35°C / 95°F).
- > Rinse and brush off all internal and external surfaces.
- > Move moving parts back and forth several times.
- > Remove any liquid residues using compressed air.



W&H recommends automated cleaning and lubrication with W&H Assistina 3x3.

> Follow the instructions in the Assistina Instructions for use.



> W&H recommends wiping down with disinfectant.



Evidence of the medical device's basic suitability for effective manual disinfection was provided by an independent test laboratory using the »mikrozid[®] AF wipes« disinfectant (Schülke & Mayr GmbH, Norderstedt).



W&H recommends automated cleaning and disinfection using a washer-disinfector (WD).

- > Read the notes, follow the instructions and heed the warnings provided by the manufacturers of washer-disinfectors, cleaning agents and/or disinfectants.



Evidence of the medical device's basic suitability for effective automated disinfection was provided by an independent test laboratory using the »Miele PG 8582 CD« washer-disinfector (Miele & Cie. KG, Gütersloh) and the »Dr. Weigert neodisher® MediClean forte« cleaning agent (Dr. Weigert GmbH & Co. KG, Hamburg).

- > Cleaning at 55 °C (131 °F) – 5 minutes
- > Disinfection at 93 °C (200 °F) – 5 minutes



- > Ensure that the medical device is completely dry internally and externally after cleaning and disinfection.
- > Remove any liquid residues using compressed air.

Inspection



- > Check the medical device after cleaning and disinfection for damage, visible residual soiling and surface changes.
- > Reprocess any medical devices that are still soiled.
- > Sterilize the reassembled medical device following cleaning, disinfection and lubrication.

Lubrication



- > Lubricate the dry medical device immediately after cleaning and/or disinfection.

Recommended lubrication cycles

- > Essential after every internal cleaning
 - > Before each sterilization
- or
- > After 30 minutes of use or at least once daily
 - > Chucking system once a week

With W&H Service Oil F1, MD-400

- > Follow the instructions on the oil spray can and on the packaging.

or

With W&H Assistina

- > Follow the instructions in the Assistina Instructions for use.

Testing after lubrication



- > Direct the medical device downwards.
- > Operate the medical device so that excess oil can escape.
- > Excess oil may result in the medical device overheating.



Pack the medical device and the accessories in sterilization packages that meet the following requirements:

- > The sterilization package must meet the applicable standards in respect of quality and use and must be suitable for the sterilization method.
- > The sterilization package must be large enough for the sterilization goods.
- > The filled sterilization package must not be under tension.



W&H recommends sterilization according to EN 13060, EN 285 oder ANSI/AAMI ST79.



- > Read the notes, follow the instructions and heed the warnings provided by the manufacturers of steam sterilizers.
- > The program selected must be suitable for the medical device.

Recommended sterilization procedures

- > Fractionated pre-vacuum process (type B)
- > Gravity displacement process (type N)
- > Sterilization time at least 30 minutes at 121°C (250°F) or at least 3 minutes at 134°C (273°F)
- > Maximum sterilization temperature 135°C (275°F)



Evidence of the medical device's basic suitability for effective sterilization was provided by an independent test laboratory using the LISA 517 B17L steam sterilizer (Firma W&H Sterilization S.r.l., Brusaporto (BG)) and the CertoClav MultiControl MC2-S09S273 gravitation sterilizer (CertoClav GmbH, Traun).

- > Fractionated pre-vacuum process (type B): temperature 134°C (273°F) – 3 minutes*
- > Gravity displacement process (type N): temperature 121°C (250°F) – 30 minutes**

* according to EN 13060, EN 285, ISO 17665 / ** according to ANSI/AAMI ST55 , ANSI/AAMI ST79



- > Store sterile goods dust-free and dry.
- > The shelf life of the sterile goods depends on the storage conditions and type of packaging.

6. Servicing

Repairs and returns

In the event of operating malfunctions immediately contact an authorized W&H service partner.

Repairs and maintenance work must only be undertaken by an authorized W&H service partner.



- > Ensure that the medical device has been completely processed before returning it.

7. W&H Accessories and spare parts



Use only original W&H accessories and spare parts or accessories approved by W&H.

Suppliers: W&H partners

000301xx	W&H Assistina 301 plus
19922000	W&H Assistina 3x2 (MB-200)
19923000	W&H Assistina 3x3 (MB-300)
30310000	W&H Assistina TWIN (MB-302)
10940021	Service Oil F1, MD-400 (6 pcs)
02038200	Spray adaptor

8. Technical data

Endea Endo Cursor		EB-62
Transmission ratio		4:1
Motor coupling in accordance with standard		ISO 3964
Recommended root canal instruments*		Root canal hand instruments
Grip diameter	(mm)	Ø 3.6 – 4
min. chuck length	(mm)	until limit stop
max. motor speed	(rpm)	6,000

* In choosing the correct operating conditions, the user must ensure that there is no risk to the user, the patient or third parties. Always follow the instructions of the manufacturer of the root canal instruments (e.g. in terms of speed, chuck length, described application).

Technical data

Endo NiTi	WD-73 M	WD-74 M
Transmission ratio	70:1	128:1
Coupling in accordance with standard	ISO 3964	
Recommended root canal instruments* Instrument shaft diameter (type 1) in accordance with ISO 1797 (mm)	NiTi-Feilen for rotation root canal preparation Ø 2.35	
min. chuck length (mm)	einrastend	
max. motor speed for NiTi files from 300-350 rpm: produces an application speed of: (rpm)	25,000 357	40,000 312
max. motor speed for NiTi files from 600 rpm: produces an application speed of: (rpm)	40,000 571	

* In choosing the correct operating conditions, the user must ensure that there is no risk to the user, the patient or third parties. Always follow the instructions of the manufacturer of the root canal instruments (e.g. in terms of speed, chuck length, described application).

Technical data

Endea	EB-75	EB-79	
Transmission ratio	16:1	2:1	
Coupling	ISO 3964		
Recommended root canal instruments* Instrument shaft diameter (Typ 1) according to standard ISO 1797	NiTi-files for rotation root canal preparation		
(mm)	Ø 2.35		
min. chuck length	engaging		
max. motor speed for NiTi files from 300-350 rpm: produces an application speed of:	5,000 312	600 300	
(rpm)			
max. motor speed for NiTi files from 600 rpm: produces an application speed of:	10,000 625	1,200 600	
(rpm)			
max. motor speed for NiTi files from 1,200-2,500 rpm: produces an application speed of:	25,000 1,562	2,500 1,250	5,000 2,500
(rpm)			

* In choosing the correct operating conditions, the user must ensure that there is no risk to the user, the patient or third parties. Always follow the instructions of the manufacturer of the root canal instruments (e.g. in terms of speed, chuck length, described application).

Temperature information

Temperature of the medical device on the operator side:

maximum 55°C (131°F)

Temperature of the medical device on the patient side:

maximum 50°C (122°F)

Temperature of the working part (rotary instrument):

maximum 41°C (105,8°F)

Ambient conditions

Temperature during storage and transport

-40°C to +70°C (-40°F to +158°F)

Humidity during storage and transport

8% to 80% (relativ), non-condensing

Temperature during operation

+10°C to +35°C (+50°F to +95°F)

Humidity during operation:

15% to 80% (relativ), non-condensing

9. Disposal



Ensure that the parts are not contaminated on disposal.

Instrument disposal



Follow your local and national laws, directives, standards and guidelines for disposal.

- > Medical device
- > Packaging

Explanation of warranty terms

This medical device has been manufactured with great care by highly qualified specialists. A wide variety of tests and controls guarantee faultless operation. Please note that claims under warranty can only be validated when all the directions in the Instructions for use have been followed.

As manufacturer, W&H is liable for material or manufacturing defects within a warranty period of 24 months from the date of purchase.

We accept no responsibility for damage caused by incorrect handling or by repairs carried out by third parties not authorized to do so by W&H!

Claims under warranty accompanied by proof of purchase, must be sent to the vendor or to an authorized W&H service partner. The provision of service under warranty extends neither the warranty period nor any other guarantee period.

24 months warranty

Authorized W&H service partner

Find you nearest W&H service partner at <http://wh.com>

Simply go to the menu option »Service« for full details. Alternatively please contact:

W&H (UK) LIMITED, Unit 6, Stroud Wood Business Centre, Park Street, St Albans, AL2 2NJ Hertfordshire
t +44 1727 874990, f +44 1727 872254, E-Mail: technical.uk@wh.com

W&H Impex Inc., 6490 Hawthorne Drive, Windsor, Ontario, N8T 1J9, Canada
t + 1 800 2656277, + 1 519 9446739, f + 1 519 9746121, E-Mail: service.ca@wh.com

W&H Impex Inc., 33091 W Jefferson Ave. Brownstown, MI-48173, USA
t + 1 800 265 6277, + 1 519 944 6739, f + 1 519 9746121, E-Mail: service.us@wh.com

W&H Austria GmbH, Ignaz-Glaser-Straße 53, 5111 Bürmoos, Austria
t + 43 6274 6236-239, f + 43 6274 6236-890, E-Mail: office.at@wh.com

A-DEC AUSTRALIA CO. INC., *Office and showroom*, Unit 8, 5-9 Ricketty Street, 2020 Mascot NSW
t + 61 2 8332 4000, f + 61 2 8332 4099, E-Mail: a-dec@a-dec.com.au

Manufacturer

W&H Dentalwerk Bürmoos GmbH
Ignaz-Glaser-Straße 53, 5111 Bürmoos, Austria

t +43 6274 6236-0, f +43 6274 6236-55
office@wh.com wh.com

Form-Nr. 50669 AEN
Rev. 004 / 24.10.2018
Subject to alterations