

Instructions for use



PEOPLE HAVE PRIORITY



Electric motor

EM-19 / EM-19 LC

Contents

Symbols

in the Instructions for use	4
on the medical device / packaging.....	5

1. Introduction	6
------------------------------	----------

2. Safety notes	9
------------------------------	----------

3. Product description.....	12
------------------------------------	-----------

4. Operation

Assembly/Removal	14
Test run	15

5. Hygiene and maintenance

General notes.....	16
Limitations on processing	18
Initial treatment at the point of use	19
Manual cleaning	20

Manual disinfection	21
Automated cleaning and disinfection	22
Drying	23
Inspection, Maintenance and Testing	24
Packaging	25
Sterilization.....	26
Storage	28
6. Servicing	29
7. W&H Accessories and spare parts.....	31
8. Technical data	32
9. Disposal	34
Explanation of warranty terms	35
Authorized W&H service partners.....	36

Symbols

in the Instructions for use



WARNING!
(risk of injury)



ATTENTION!
(to prevent
damage occurring)



General explanations,
without risk to
persons or objects



Do not dispose of with
domestic waste

R_x_{only}

Caution!

According to Federal law, this medical device may only be sold by or on the order of a dentist, physician or any other medical practitioner licensed by the law of the State in which he or she practices, and who intends to use or order the use of this medical device.

Symbols

on the medical device / packaging



CE marking
with identification number
of the Notified Body



DataMatrix Code
for product information
including UDI (Unique
Device Identification)



Type B applied part (not
suitable for intracardiac
application)



Catalogue number



Thermo washer
disinfectable



UL Component Recognition
Mark indicates compliance
with Canadian and U.S.
requirements



Serial number



Sterilizable up to the
stated temperature



Data structure in
accordance with
Health Industry Bar Code



Date of manufacture



Permitted temperature
range



Humidity,
Limitation

1. Introduction

Customer satisfaction has absolute priority in the W&H quality policy. This medical device has been developed, manufactured and subjected to final inspection according to legal regulations, quality and industry standards.

For your safety and the safety of your patients

Prior to initial use please read the Instructions for use. These explain how to use your medical device and guarantee a smooth and efficient operation.



Observe the safety notes.

Intended use

Electrical drive for transmission instruments with ISO 3964 (DIN 13940) compatible coupling system, for use in dental surgery, implantology and maxillofacial surgery (CMF).



Misuse may damage the medical device and hence cause risks and hazards for patient, user and third parties.

Qualifications of the user

Only suitably qualified medical, technical and specialist trained staff may use the W&H Implantmed.
We have based our developed and design of the Implantmed on the »physician« target group.



Production according to EU Directive

The medical device meets the requirements of Directive 93/42/EEC.

Responsibility of the manufacturer

The manufacturer can only accept responsibility for the safety, reliability and performance of the medical device when it is used in compliance with the following directions:

- > The medical device must be used in accordance with these Instructions for use.
- > The medical device has no components that can be repaired by the user.
- > Modifications or repairs must only be undertaken by an authorized W&H service partner (see page 36).



HF communication equipment

Do not use any portable and mobile HF communication equipment (e.g. mobile telephones) during operation. These may affect medical electrical equipment.

Skilled application

The medical device is intended only for skilled application according to the intended use as well as in compliance with the valid health and safety at work regulations, the valid accident prevention regulations and in compliance with these Instructions for use.

The medical device should be prepared for use and maintained by staff who have been trained in procedures for infection control, personal safety and patient safety.

Improper use, (e.g., through poor hygiene and maintenance), non-compliance with our instructions or the use of accessories and spare parts which are not approved by W&H, invalidates all claims under warranty and any other claims.

2. Safety notes

-  > Before using the medical device for the first time, store it at room temperature for 24 hours.
- > Check the medical device for damage and loose parts each time before using.
- > Do not operate the medical device if it is damaged.
- > Always ensure the correct operating conditions.
- > Check the parameter settings every time the device is restarted.
- > Perform a test run each time before using.
- > Ensure that it is possible to complete the operation safely should the units or instruments fail.

-  > Do not twist or kink the motor cable! Do not coil it too tightly!
- > Moisture in the medical device may cause a malfunction! (Risk of short circuit)
- > The medical device must not be disassembled.
- > The medical device must not be oiled (pre-oiled for entire service life).

 The medical device is not approved for operation in potentially explosive atmospheres.



Risks due to electromagnetic fields

The functionality of implantable systems, such as cardiac pacemakers and implantable cardioverter defibrillator (ICD) can be affected by electric, magnetic and electromagnetic fields.

- > Find out if patient and user have implanted systems before using the medical device and consider the application.
- > Weigh the risks and benefits.
- > Keep the medical device away from implanted systems.
- > Make appropriate emergency provisions and take immediate action on any signs of ill-health.
- > Symptoms such as raised heartbeat, irregular pulse and dizziness can be signs of a problem with a cardiac pacemaker or ICD.



Rotational energy

Fast deceleration of the bur can, at times, cause the selected torque to be temporarily exceeded, compared to the value set, as a result of the rotational energy stored in the drive system.



Transmission instruments

- > Follow the directions and safety notes in the Instructions for Use of the transmission instruments.
- > Only use transmission instruments with an ISO 3964 (DIN 13940) compatible coupling system and manufacturer approved transmission instruments.
- > Follow the directions of the manufacturer of transmission instruments with reference to transmission ratio, maximum speed and maximum torque.



Hygiene and maintenance prior to initial use

- > The medical device is packaged in PE bag and not sterilized when delivered.
- > The PE bag and the packaging are non-sterilizable.

- > Clean and disinfect the medical device.
- > Sterilize the medical device.

3. Product description

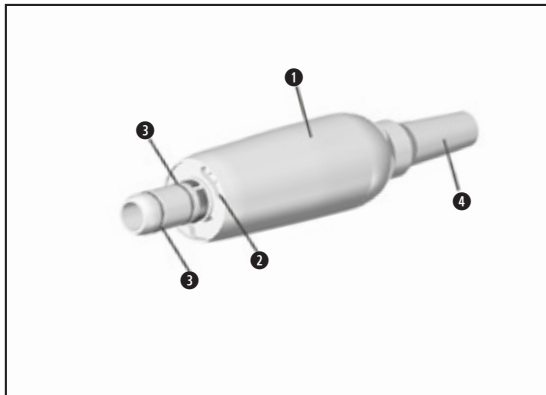

- ① Motor sheath
- ② Electrical contacts*
- ③ O-Ring
- ④ Motor cable

*only EM-19 LC

4. Operation

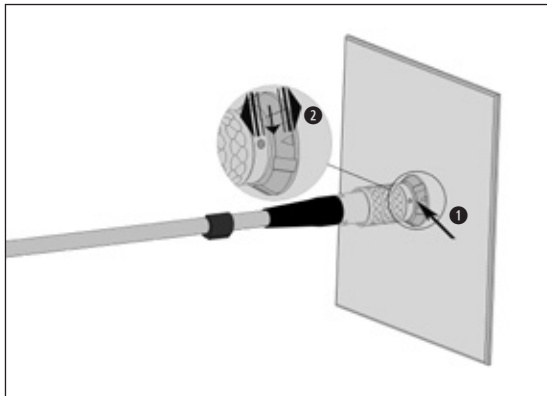

Do not assemble or remove the medical device during operation!

1

Connect motor cable.



Pay attention to the positioning.



2

Verify full engagement.

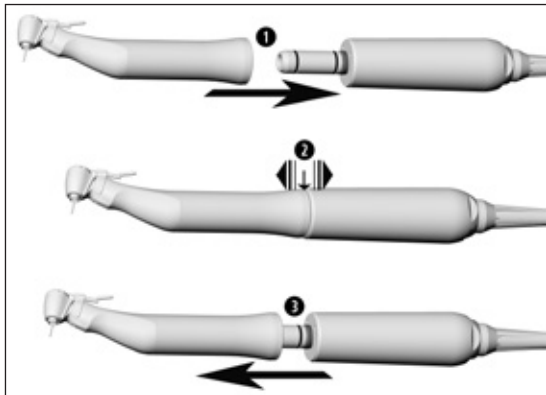

Do not assemble or remove the medical device during operation!

- 1** Push the transmission instrument onto the medical device and turn it until it engages audibly.



- 2** Verify full engagement.

- 3** Remove the transmission instrument from the medical device by pulling in an axial direction.

Test run



Do not hold the medical device at eye level.

- > Start the medical device using the attached transmission instrument.



In the event of operating malfunctions (e.g., vibrations, unusual noise, overheating) **stop the medical device immediately** and contact an authorized W&H service partner.



- > Follow your local and national laws, directives, standards and guidelines for cleaning, disinfection and sterilization.



- > Wear protective clothing, safety glasses, face mask and gloves.
- > Remove the transmission instrument from the medical device.



- > Use only oil-free, filtered compressed air with a maximum operating pressure of 3 bar for manual drying.



Cleaning agents and disinfectants

- > Read the notes, follow the instructions and heed the warnings provided by the manufacturers of cleaning agents and/or disinfectants.
- > Use only detergents which are intended for cleaning and/or disinfecting medical devices made of metal and plastic.
- > It is imperative to comply with the concentrations and exposure times specified by the manufacturer of the disinfectant.
- > Use disinfectants which have been tested and found effective by the Verbund für Angewandte Hygiene e.V. (VAH = Association for Applied Hygiene), the Österreichischen Gesellschaft für Hygiene, Mikrobiologie und Präventivmedizin (ÖGHMP = Austrian Society for Hygiene, Microbiology and Preventive Medicine), the Food and Drug Administration (FDA) and the U.S. Environmental Protection Agency (EPA).



The user is responsible for validating its process if the specified cleaning agents and disinfectants are not available.



The product lifetime and the medical device's ability to operate correctly are mainly determined by mechanical stress during use and chemical influences due to processing.

- > Send worn or damaged medical devices and/or medical devices with material changes to an authorized W&H service partner.



Processing cycles

- > We recommend a regular service for the W&H medical device after 500 processing cycles or one year.



- > Clean and disinfect the medical device immediately after every treatment.
- > Wipe the entire surface of the medical device with disinfectant.



Note that the disinfectant used during pre-treatment is only for personal protection and cannot replace the disinfectant step after cleaning.



Do not place the medical device in liquid disinfectant or in an ultrasonic bath.

- > Clean the medical device under running tap water (<35°C / 95°F).
- > Rinse off all surfaces.
- > Remove any liquid residues using compressed air.



> W&H recommends wiping down with disinfectant.



Evidence of the medical device's basic suitability for effective manual disinfection was provided by an independent test laboratory using the »mikrozid® AF wipes« disinfectant (Schülke & Mayr GmbH, Norderstedt).



W&H recommends automated cleaning and disinfection using a washer-disinfector (WD).

- > Read the notes, follow the instructions and heed the warnings provided by the manufacturers of washer-disinfectors, cleaning agents and/or disinfectants.



Evidence of the medical device's basic suitability for effective automated disinfection was provided by an independent test laboratory using the »Miele PG 8582 CD« washer-disinfector (Miele & Cie. KG, Gütersloh) and the »Dr. Weigert neodisher® MediClean forte« cleaning agent (Dr. Weigert GmbH & Co. KG, Hamburg).

- > Cleaning at 55°C (131°F) – 5 minutes
- > Disinfection at 93°C (200°F) – 5 minutes



- > Ensure that the medical device is completely dry internally and externally after cleaning and disinfection.
- > Remove any liquid residues using compressed air.

Inspection



- > Check the medical device after cleaning and disinfection for damage, visible residual soiling and surface changes.
- > Reprocess any medical devices that are still soiled.
- > Sterilize the reassembled medical device following cleaning and disinfection.



Pack the medical device and the accessories in sterilization packages that meet the following requirements:

- > The sterilization package must meet the applicable standards in respect of quality and use and must be suitable for the sterilization method.
- > The sterilization package must be large enough for the sterilization goods.
- > The filled sterilization package must not be under tension.



W&H recommends sterilization according to EN 13060, EN 285 oder ANSI/AAMI ST79.



- > Read the notes, follow the instructions and heed the warnings provided by the manufacturers of steam sterilizers.
- > The program selected must be suitable for the medical device.

Recommended sterilization procedures

- > Fractionated pre-vacuum process (type B)
- > Gravity displacement process (type N)
- > Sterilization time at least 30 minutes at 121°C (250°F) or at least 3 minutes at 134°C (273°F)
- > Maximum sterilization temperature 135°C (275°F)



Evidence of the medical device's basic suitability for effective sterilization was provided by an independent test laboratory using the LISA 517 B17L steam sterilizer (Firma W&H Sterilization S.r.l., Brusaporto (BG)) and the CertoClav MultiControl MC2-S09S273 gravitation sterilizer (CertoClav GmbH, Traun).

- > Fractionated pre-vacuum process (type B): temperature 134°C (273°F) – 3 minutes*
- > Gravity displacement process (type N): temperature 121°C (250°F) – 30 minutes**

* according to EN 13060, EN 285, ISO 17665 / ** according to ANSI/AAMI ST55 , ANSI/AAMI ST79



- > Store sterile goods dust-free and dry.
- > The shelf life of the sterile goods depends on the storage conditions and type of packaging.

6. Servicing



Regular checks

Regular servicing of function and safety including the accessories is necessary and should be carried out at least once every three years, unless shorter intervals are prescribed by law. The inspection must be undertaken by a qualified organization and must include the following procedures:

- > Visual inspection of internal components on suspicion of safety interference, e.g., mechanical damage of the cable.



The regular inspection must only be performed by an authorized W&H service partner.

Repairs and returns

In the event of operating malfunctions immediately contact an authorized W&H service partner. Repairs and maintenance work must only be undertaken by an authorized W&H service partner.



> Ensure that the medical device has been completely processed before returning it.

7. W&H Accessories and spare parts



Use only original W&H accessories and spare parts or accessories approved by W&H.

Suppliers: W&H partners

04363600 Disposable irrigation tubing set 2.2 m (6 pcs)

06290600 Hose clips (5 pcs)

8. Technical data

Motor	EM-19 / EM-19 LC
Direction of rotation	forward/reverse
Speed range	200 – 40.000 rpm
Maximum torque at the motor	6,2 Ncm
Coolant volume flow at 100%:	min. 90 ml/min
Maximum power output:	80 W

Temperature information



Temperature of the medical device on the operator side: maximum 55°C (131°F)

Ambient conditions

Temperature during storage and transport:

-40°C to +70°C (-40°F to +158°F)

Humidity during storage and transport:

8% to 80% (relativ), non-condensing

Temperature during operation:

+10°C to +35°C (+50°F to +95°F)

Humidity during operation:

15% to 80% (relativ), non-condensing

Altitude:

up to 3,000 m above sea level

9. Disposal



Ensure that the parts are not contaminated on disposal.



Follow your local and country-specific laws, directives, standards and guidelines for disposal.

- > Medical device
- > Waste electrical equipment
- > Packaging

Explanation of warranty terms

This medical device has been manufactured with great care by highly qualified specialists. A wide variety of tests and controls guarantee faultless operation. Please note that claims under warranty can only be validated when all the directions in the Instructions for use have been followed.

As manufacturer, W&H is liable for material or manufacturing defects within a warranty period of 24 months from the date of purchase. Accessories and consumables are not covered by the warranty.

We accept no responsibility for damage caused by incorrect handling or by repairs carried out by third parties not authorized to do so by W&H!

Claims under warranty accompanied by proof of purchase, must be sent to the vendor or to an authorized W&H service partner. The provision of service under warranty extends neither the warranty period nor any other guarantee period.

24 months warranty

Authorized W&H service partners

Visit W&H on the Internet at <http://wh.com>

You can find your nearest W&H service partner under “Service” in the menu.

If you do not have Internet access, please contact:

W&H (UK) Limited, Unit 6, Stroud Wood Business Centre, Park Street, St Albans, AL2 2NJ Hertfordshire
t +44 1727 874990, f +44 1727 872254, E-Mail: technical.uk@wh.com

W&H Impex Inc., 6490 Hawthorne Drive, Windsor, Ontario, N8T 1J9, Canada
t +1 519 944 6739, f +1 519 974 6121, E-Mail: service.ca@wh.com

W&H Austria GmbH, Ignaz-Glaser-Straße 53, 5111 Bürmoos, Austria
t +43 6274 6236-239, f +43 6274 6236-890, E-Mail: office.at@wh.com

A-DEC Australia, *Office and showroom*, Unit 8, 5-9 Ricketty Street, 2020 Mascot NSW
t +61 2 8332 4000, f +61 2 8332 4099, E-Mail: a-dec@a-dec.com.au

Manufacturer

W&H Dentalwerk Bürmoos GmbH
Ignaz-Glaser-Straße 53, 5111 Bürmoos, Austria

t + 43 6274 6236-0, f + 43 6274 6236-55
office@wh.com wh.com

Form-Nr. 50983 AEN
Rev. 000 /23.08.2018
Subject to alterations